

TEMPTEK DESICCANT DRYER

- **Self-Contained Dryer/ Hopper Design**
- **Throughput 15 - 50 lb/hr**
- **3 Models to choose from:**
 - **NDB-15-T**
 - **NDB-25-T**
 - **NDB-50-T**

**In Stock
Quick Shipment!**

TempTek desiccant dryers use the industry standard dual-bed drying concept in a compact single blower configuration. One blower and multi-function valve control both the process and regeneration flow and the heaters are contained within the desiccant beds to minimize space.

- Guaranteed -40°F dewpoint process air
- Dual bed, stainless steel construction
- Integrated stainless steel insulated drying hoppers with large access door and sight glass (200 lb. hopper is carbon steel)
- Compact design with single blower and a multi-function valve to control both the process and regeneration heaters contained within the desiccant beds to save space.
- Standard voltage 115/1/60 for NDB-15-T, 460/1/60 for NDB-25-T and 460/3/60 for NDB-50-T
- Cyclonic 2 stage process filter
- High heat up to 350° F (cooling coil required over 225° F)
- Tubular Incoloy® sheath heaters
- Nema 1 enclosure
- Main line contactor
- High efficiency 13X molecular sieve desiccant
- Slide gate shut off
- Analog thermometer at hopper inlet
- 1 Year warranty
- **MADE IN THE USA!**

Authorized Dealer

Southgate Process Equipment, Inc.

87 Hickory Springs IND. Drive

Canton, GA 30115

Ph: (770) 345-0010

Email: sales@southgatepe.com



NDB-25-T

Micro PLC Based Control

- Over-temperature alarm and shutdown with indication
- Auto-tune PID temperature control with dual LED display
- Full function graphic display.

PRICE & PERFORMANCE... for the LONG TERM

87 Hickory Springs IND. Drive Canton, GA 30115 Ph: (770) 345-0010 Website: www.Southgatepe.com Email: sales@southgatepe.com

TEMPTEK®

since 1989

SPECIFICATIONS

Model	Process Rate* lb/hr	Overall Dimensions			Mounting Pattern (B) in	Voltage	Hopper Sizes	Weight lb
		W in	D in	H in				
NDB-15-T	15	35	29	50	4.75	115/1/60	60	500
NDB-25-T	25	35	29	50	4.75	460/1/60	100	530
NDB-50-T	50	43	30	60	6.0	460/3/60	200	725

* Nominal throughput, based on polycarbonate pellets at 38 lb./ft³.

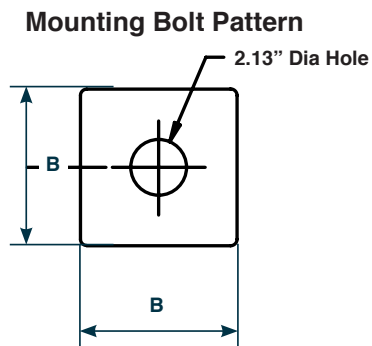
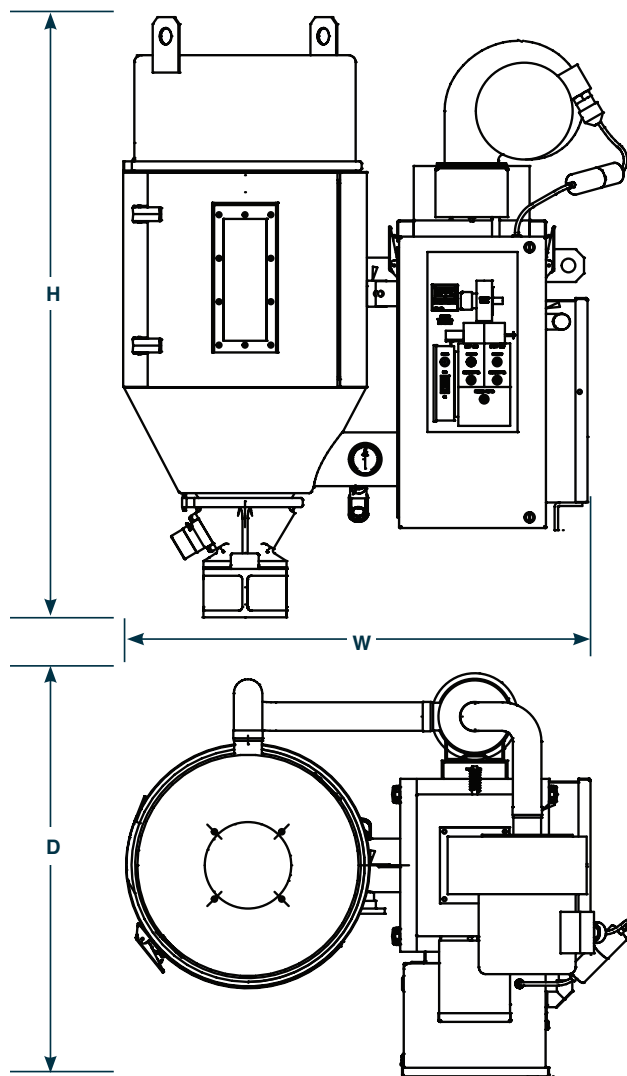

For best pricing call Southgate Process Equipment @ (770) 345-0010

PRICE & PERFORMANCE... for the LONG TERM



since 1989

87 Hickory Springs IND. Drive Canton, GA 30115 Ph: (770) 345-0010 Website: www.Southgatepe.com Email: sales@southgatepe.com